

SELF-HEALING OF FIBER REINFORCED POLYMER COMPOSITES

Nebiyu Fikru
M.S. Candidate

Faculty Advisor: Eyassu Woldesenbet

ABSTRACT

The study of self-healing materials is inspired by biological systems in which damage triggers an autonomous healing response. In recent years, this concept of autonomic healing material, where initiation of repair is integral to the material, is being considered for engineering applications. The concept offers the designer an ability to incorporate secondary functional ability of counteracting service degradation whilst still achieving the primary, usually structural, requirement. Self-healing materials are composite materials that have the benefit of offering lighter and optimized structures as well as reduced maintenance cost. Previous works in composites such as polymer matrix composites have shown that significant fractions of mechanical properties can be restored through self-healing in damaged materials.

The self-healing composite material presented in this study is fiber-reinforced polymer matrix composite. A single fiber reinforced polymer matrix self-healing composite system is developed and analyzed in the initial study. In the latter stage of the study, multiple fibers are used as the reinforcing material in the self-healing composite system. The self-healing approach utilizes a releasable healing agent (dicyclopentadiene/DCPD) contained in a hollow fiber that is embedded in a resin system. All Specimens are produced using a hollow glass fiber and epoxy resin. Moreover, in the case of multiple fiber test, e-glass fiber is incorporated in the composite. When a crack is initiated and propagates through the composite breaking the hollow fiber, a liquid healing agent comes out and fills the crack gap. Polymerization of the monomer healing agent is facilitated when it contacts a catalyst (Grubb's catalyst) that is pre-coated on the outside surface of the hollow glass fiber. The inclusion of functionalized carbon nanotubes in further enhancing the healing process is considered at the final stage of the study.

Healed, damaged and virgin specimens are tested in tension for all the different sets of composite systems investigated. The experiments show that self-healing is achieved in fiber reinforced polymer matrix composites with high degree of restoration of the original tensile

strength for a single fiber polymer composite that is damaged at one place. The self-healing composite includes a healing agent, a catalyst, a hollow fiber, and resin.

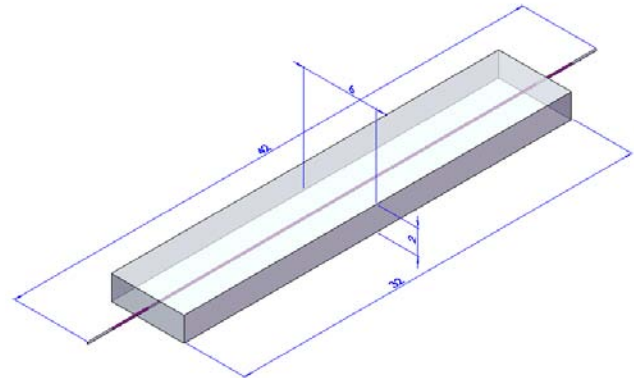

Schematic diagram of a single fiber polymer matrix composite

The catalyst is placed on the outer surface of the hollow fiber to avoid untimely polymerization. When the hollow fiber breaks due to the propagation of cracks, the healing agent, a DCPD mixture (DCPD and chloroform) is released. The healing agent then fills the gap in the fiber and matrix crack volume, and heals the crack after the healing agent polymerizes when it comes in contact with the Grubb's catalyst on the surface of the fiber. Other configurations of fiber reinforced polymer matrix composite are also tested in order to characterize the effect of the catalyst and damage on the composite. The catalyst is found to have no deteriorating effect on the fiber-matrix interface. Unhealed or damaged specimen that contains a broken fiber with no or minimal healing has produced a much lower tensile strength. The presence of the healing agent, a DCPD mixture, the Grubb's catalyst, and their appropriate placement in a fiber reinforced polymer composite confirms the possibility of self-healing in fully integrated structural fiber reinforced composites. If the damage on the specimen is at two places, a considerable healing efficiency is obtained, showing that multiple damages as well can be healed significantly. A major advantage is achieved when

the self-healing is found to be localized allowing further multiple healing of the composite in the presence of several cracks. Tensile toughness has also shown to increase dramatically in the composite where carbon nanotube is incorporated in the healing medium.

Average tensile strength, standard deviation and healing efficiency for the single damage/single healing specimens

Specimen	Tensile Strength (MPa)	Standard Deviation (MPa)	Healing Efficiency (%)
Virgin(Filled)	38.2	0.45	100
Virgin(Hollow)	37.9	0.44	99.2
Damaged	26.9	0.81	70.5
Healed	34.6	0.6	90.7
Broken	0	0	0

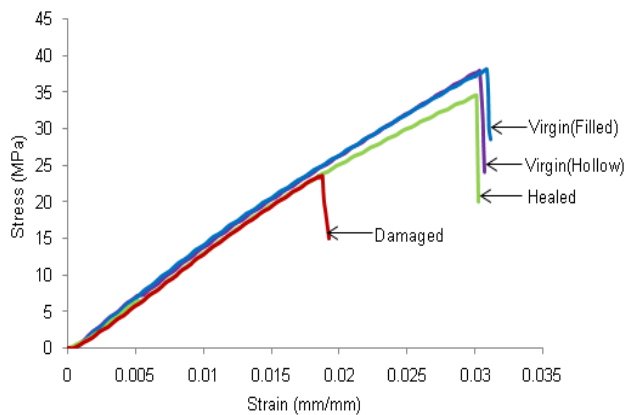

ACKNOWLEDGMENTS

My deepest gratitude goes to Dr. Eyassu Woldesenbet, for guiding me throughout this new research in self-healing composites. I would also like to thank the support from National Science Foundation.

REFERENCES

1. Dry C. (1996). Procedures Developed for Self-Repair of Polymeric Matrix Composite Materials, *Composite Structures*, 35:263-269.
2. White, S.R., N. R. Sottos, P. H. Geubelle, J. S. Moore, M. R. Kessler, S.R. Sriram, E.N Brown and S. Viswanathan (2001). Autonomic healing of polymer composites, *Nature*, 409:794-797. Put references here.

3. Grubbs, R. H. and W. Tumas (1989). Polymer synthesis and organotransition metal chemistry. *Science* 243, 907-915.
4. Wool R.P. and K.M. O’Conner (1982). A theory of crack healing in polymers, *Journal of Applied Physics*, 52:5953-5963.